

Japanese Kokai Patent Application No. Hei 11[1999]-49903

Job No.: 417-106619

Ref.: 2002B107-A – Job No. 813,508

Translated from Japanese by the McElroy Translation Company

800-531-9977

customerservice@mcelroytranslation.com

JAPANESE PATENT OFFICE
PATENT JOURNAL (A)
KOKAI PATENT APPLICATION NO. HEI 11[1999]-49903

Int. Cl.^[illegible]: C 08 L 23/04
B 32 B 27/32
C 08 J 5/18
C 08 K 5/01

Filing No.: Hei 9[1997]-221014

Filing Date: August 1, 1997

Publication Date: February 23, 1999

No. of Claims: 6 (Total of 7 pages; FD)

Examination Request: Not filed

POLYETHYLENE RESIN COMPOSITION AND FILM MADE THEREFROM

Inventors: Yoshihiko Sasaki
Yokkaichi Technology Center
Nippon Polykemu K.K.
1 Toho
Yokkaichi, Mie

Kazutoshi Takenaka
Yokkaichi Technology Center
Nippon Polykemu K.K.
1 Toho
Yokkaichi, Mie

Applicant: 596133485
1-10-1 Yurakucho
Chiyodaku, Tokyo

Agent: Kenji Kawanobu, patent attorney

[There are no amendments to this patent.]

Abstract**Problem**

To provide a polyethylene resin composition and film therefrom, desirable for a pressure-sensitive adhesive layer capable of giving a pallet stretch film with pressure-sensitive self-adhesiveness, has good pressure-sensitive adhesiveness between films, can be easily peeled and has good opening properties, while no expensive pressure-sensitive adhesives are used.

Means to solve

Polyethylene resin composition and film made therefrom, characterized by containing 99-80 wt% polyethylene resin and 1-20 wt% process oil.

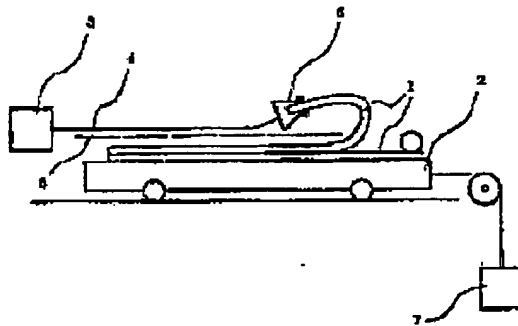
Claims

1. Polyethylene resin composition, characterized by containing 99-80 wt% polyethylene resin and 1-20 wt% process oil.
2. Polyethylene resin composition described in Claim 1, wherein the polyethylene resin has a melt-flow rate of 0.1-100 g/10 min and density 0.86-0.94 g/cm³.
3. Polyethylene resin composition described in Claim 1 or 2, wherein the polyethylene resin has a Q value below 4.
4. Polyethylene resin composition described in Claims 1-3, wherein the process oil is a paraffin oil with a weight-average molecular weight of 200-2000.
5. Film characterized by being made from polyethylene resin composition described in Claims 1-4.
6. Film described in Claim 5, used for the outermost and/or innermost layer of pallet stretch film.

Detailed description of the invention

[0001]

Technical field of the invention

The present invention concerns a polyethylene resin composition desirable for a pressure-sensitive adhesive layer capable of giving a pallet stretch film with pressure-sensitive self-adhesiveness, has good pressure-sensitive adhesiveness between films, can be easily peeled and has good opening properties; it especially concerns polyethylene resin compositions and films made therefrom suitable for pressure-sensitive adhesive layers of pallet stretch films.

[0002]

Prior art

The typical layer constitution of pallet stretch films comprises three layers including ethylene-vinyl acetate copolymer (hereafter referred to as EVA) pressure-sensitive adhesive for the inner and outer layers and linear low-density polyethylene (hereafter referred to as LLDPE) for the interlayer. For example, in forming such multilayer inflation films, the film is cut at both ends to divide the film into two and wound on a paper tube, or the cut film is repelletized, blended with LLDPE and fed into the hopper for the interlayer molding machine to form a film. Here, when mixing LLDPE with regenerated pellets, the film strength decreases by about 20%. This is due to mixing of EVA with the regenerated pellets. Thus, EVA-free film, i.e., a multilayer film with all layers being LLDPE is desirable.

[0003]

However, with conventional LLDPE used as the pressure-sensitive adhesive, pressure-sensitive adhesive properties are not sufficient, and are thus not suitable for practical application. More recently, density reduction of low-density polyethylene enabled by using metallocene catalysts, etc., has resulted in increased pressure-sensitive adhesive strength, but blocking occurs during film formation, making film separation and practical application impossible. While pressure-sensitive adhesives are compounded in the pressure-sensitive adhesive layer, such as expensive liquid polybutene, sorbitan oleate esters, diglycerol dioleate, etc., leading to a high unit price of the film, development of a pressure-sensitive adhesive layer with the desired pressure-adhesive properties without using expensive pressure-sensitive adhesives is desired.

[0004]

Problems to be solved by the invention

It is an objective of the present invention to provide a polyethylene resin composition and film therefrom desirable for a pressure-sensitive adhesive layer capable of giving a pallet stretch film with pressure-sensitive self-adhesiveness, has good pressure-sensitive adhesiveness between films, can be easily peeled and has good opening properties, while no expensive pressure-sensitive adhesives are used.

[0005]

Means to solve the problems

As a result of an intense investigation of means for providing films desirable for a pressure-sensitive adhesive layer capable of giving a pallet stretch film with pressure-sensitive self-adhesiveness, has good pressure-sensitive adhesiveness between films, can be easily peeled and has good opening properties, while no expensive pressure-sensitive adhesives are used, we have discovered that such objectives of the present invention can be achieved by compounding polyethylene resins with certain properties with process oil in a specific ratio. Thus, the present invention has been attained.

[0006]

Namely, the present invention concerns a polyethylene resin composition characterized by containing 99-80 wt% polyethylene resin and 1-20 wt% process oil, while the polyethylene resin has a melt-flow rate of 0.1-100 g/10 min and density of 0.86-0.94 g/cm³, and also concerns films made from these compositions.

[0007]

Embodiments of the invention

The polyethylene resin compositions according to the present invention may display sufficient performance properties even when used as a single-ply film. However, when multilayer films comprising a film layer of polyethylene resin composition according to the present invention and other polyethylene resin layers are used, further superior performance properties are displayed for pallet stretch films, even in terms of tear strength.

[0008]

Here, the word "comprising" means that the resin layer according to the present invention can be the outermost layer or innermost layer, and the other layer may be another polyethylene resin layer made up of multiple layers and types; also the resin layer according to the present

invention can be the outermost layer and the innermost layer, and the other layer may be another polyethylene resin layer made up of multiple layers and types. As long as the objectives of the present invention are achieved, it is not necessary to place the resin layer according to the present invention and the other polyethylene resin layer over the entire film face; thus, the present invention also includes films of such type.

[0009]

Next, the components, production method and films of the present invention are explained.

1. Polyethylene resin

The polyethylene resin compositions according to the present invention are characterized by containing polyethylene resin and process oil in a specific ratio. It is preferred to use polyethylene resins with the following properties (1), (2) and (3).

[0010]

(1) The polyethylene resin used in the present invention should have a JIS-K7210 melt-flow rate (MFR) of 0.1-100 g/10 min, preferably 0.3-80 g/10 min, more preferably 0.5-50 g/10 min. With a MFR higher than the range shown above, the heat resistance and film strength are low and the film formation is unstable, which is undesirable. On the other hand, with a MFR lower than the range given above, the resin pressure increases, resulting in a poor extrusion property, which is undesirable.

[0011]

(2) The polyethylene resin used in the present invention should have a JIS-K7112 density of 0.86-0.94 g/cm³, preferably 0.865-0.935 g/cm³. With the density higher than the range given above, the self-adhesion property is poor and there is a reduced self-adhesive property between films, which is not desirable. On the other hand, with the density lower than the range given above, blocking occurs between films making separation of the films impossible, which is also undesirable.

[0012]

(3) The polyethylene resins used in the present invention should have a Q value (weight-average molecular weight/number-average molecular weight) below 4, preferably below 3, especially below 2.7 as measured by size exclusion chromatography (SEC). With a Q value

exceeding the range given above, the film surface becomes rough and reduced self-adhesion properties and pressure-sensitive adhesive property between films occur, which is undesirable.

[0013]

2. Method for the manufacture of the polyethylene resin

The polyethylene resins used in the present invention are ethylene- α -olefin copolymers, and there are no particular restrictions on the catalysts or production method for making such copolymers. The catalysts may be, e.g., Ziegler catalysts (supported or unsupported combination of halogen-containing titanium compound and organoaluminum compound), Phillips catalysts (i.e., based on supported chromium oxide (Cr^{6+})), Kaminski catalysts (i.e., supported or unsupported combination of metallocene compound and organoaluminum compound, especially alumoxane). The polymerization may be carried out in the presence of such catalysts by a slurry process, gas-phase fluidized-bed process (e.g., Japanese Kokai Patent Application No. Sho 59[1984]-23011), solution process and high-pressure bulk polymerization process under pressure of at least 200 kg/cm^2 at polymerization temperature of 130°C or higher.

[0014]

The polyethylene resins according to the present invention should have a relatively narrow molecular weight distribution, and using Kaminski catalysts is especially preferred. Detailed production methods are disclosed in Japanese Kokai Patent Application Nos. Sho 58[1983]-19309, Sho 59[1984]-95292, Sho 60[1985]-35005, Sho 60[1985]-35006, Sho 60[1985]-35007, Sho 60[1985]-35008, Sho 60[1985]-35009, Sho 61[1986]-130314, and Hei 03[1991]-163088, European Patent No. 420,436, US Patent No. 5,055,438, International Publication No. WO91/04257, etc., using metallocene catalysts and metallocene/alumoxane catalysts; polymerization of mainly ethylene with C_{3-18} α -olefin using catalysts from stable ion compounds obtained by reacting metallocene compounds and metallocene catalysts as disclosed in WO92/07123.

[0015]

The α -olefins used as comonomers are C_{3-18} 1-olefins, such as propylene, 1-butene, 1-pentene, 1-hexene, 1-octene, 1-heptene, 4-methylpentene-1, 4-methyl-1-hexene, 4,4-dimethyl-1-pentene, etc. The α -olefin comonomers used are not limited to just one, and two or more can be used to make multimonomer copolymers such as terpolymers.

[0016]

3. Process oil

The process oil used in the present invention should have a weight-average molecular weight of 200-2000, preferably 300-1500. Such process oils are mixtures of aromatics, naphthenes and paraffins. Oil with a paraffin chain carbon content above 50 wt% with respect to the total carbon is called paraffin oil. Oil with a naphthenic ring carbon content of 30-45 wt% with respect to the total carbon is called naphthenic oil. Oil with an aromatic carbon content above 30 wt% is called aromatic oil. Of these, paraffin oil is preferred for heat resistance.

[0017]

The paraffin oils used in the present invention should have a 40°C kinematic viscosity of 20-800 cSt (centistokes), preferably 50-600 cSt, a pour point of -40 to 0°C, preferably -30 to 0°C, and a flash point (COC) of 200-400°C, preferably 250-350°C.

[0018]

4. Compounding ratio of polyethylene resin and process oil

In the present invention, the compounding ratio of polyethylene resin and process oil is 99-80 wt% of polyethylene resin to 1-20 wt% of process oil, preferably 98.7-83 wt% of polyethylene resin to 1.3-17 wt% of process oil. A process oil content higher than the range given above results in poor film formation, bridging under the extrusion machine hopper and surging leading to extrusion variation. This is undesirable. A process oil content lower than the range given above results in blocking between films with difficulty in separation and poor pressure-sensitive adhesion property.

[0019]

5. Method for the manufacture of the polyethylene resin composition

Making polyethylene resin compositions of the present invention containing polyethylene resin and process oil in a certain ratio can be achieved by compounding the polyethylene resin and process oil according to a conventional method for making polyethylene resin compositions. Specifically, first, the polyethylene resin and process oil are dry-blended and fed into the hopper of a film-forming machine, or they are melt-kneaded in an extruder, brabender plastograph, Banbury mixer, kneader, blender, etc., palletized in the conventional manner and formed into films.

[0020]

The polyethylene resin compositions containing polyethylene resin and process oil may be compounded with commonly used additives such as antioxidants (preferably phenolic and phosphoric acid type antioxidants), antiblocking agents, slip agents, thermal stabilizers, UV absorbers, neutralizers, antifogging agents, colorants, antimicrobial agents and/or adhesives, etc. Within the range where there are no adverse effects on the present invention, polymers from other copolymerizable monomers, e.g., high-pressure low-density polyethylene, linear low-density polyethylene, etc., may be compounded in an amount of 5-30 wt% with respect to the total weight of polyethylene resin composition containing polyethylene resin and process oil.

[0021]

6. Formation of singly-ply film and multilayer film

The polyethylene resin compositions according to the present invention may be used as films alone or as laminates with other polyethylene resins for pallet stretch films. When the layer of polyethylene resin composition according to the present invention is laminated with other polyethylene resin layers, the shape and lamination of each layer are determined as desired. For example, according to conventional multilayer film formation processes, each layer is formed in a film form separately and adhered to form a laminate, or each layer is formed and laminated at the same time by extrusion. In the case of the former, the film may be formed by the air-cooled inflation process, air-cooled two-stage inflation process, T-die film formation, water-cooled inflation process, etc. The latter process of extrusion may be carried out by the extrusion lamination process, dry lamination process, sandwich lamination process, coextrusion process (coextrusion without an adhesive layer, coextrusion with an adhesive layer, coextrusion with the compounding of an adhesive resin), etc. In the present invention, various multilayer films can be formed by any of said processes.

[0022]

In a typical embodiment of the pallet stretch film according to the present invention, the resin layer comprising polyethylene resin and process oil has a self-adhesion property with excellent pressure-sensitive adhesive strength, while peeling is easily done when desired and it is in a film form when installed as the innermost layer or outermost layer or as the innermost and outermost layers. When the polyethylene resin composition of the present invention is used as a single-ply film, the film can be formed by the inflation molding process, T-die film-forming process, etc. described above.

[0023]

Application examples

Next, the present invention is explained in further detail with application examples and comparative examples. Property measurements and film property evaluation in the examples are performed with the methods given below.

[0024]

1. Measurement of physical properties

(1) MFR: based on JIS-K7210 (190°C, 2.16 kg load)

(2) Density: based on JIS-K7112

(3) Q value: measured by size exclusion chromatography under the conditions given below to obtain it from weight-average molecular weight and number-average molecular weight. Using a universal calibration curve of monodisperse polystyrene, the molecular weight of linear polyethylene was obtained.

Machine: Waters Model 150C GPC

Solvent: o-dichlorobenzene

Flow rate: 1 mL/min

Temperature: 140°C

Measurement concentration: 2 mg/mL

Injection: 200 μ L

Column: AD80M S, three columns, product of Showa Denko Co.

[0025]

2. Film property evaluation

(1) 180° Peel strength (schematic diagram in Figure 1)

An inflation-molded film (two film sheets with inner faces joined together) was cut to 100 mm in width and 200 mm in length in a thermostat chamber at 23°C, separated into two films which were then joined with inner face to outer face and a 15-kg load was applied for 5 min. Then, the 180° peel strength was measured using a slip tester (HEIDON-14, product of Shinto Kagaku Co.) wherein a smooth plate is moved rapidly by 200-g load applied to its front end. More specifically, the two overlapped films were placed on the smooth plate with bottom film fixed and the upper film held by a clip. The clip was tied to load meter by a monofilament. The clip was placed on paper spread on the upper film. The smooth plate was moved rapidly. The maximum strength at 180° peeling of the two films is given as the 180° peel tack strength.

[0026]

(2) 180° blocking peel strength

An inflation-molded film (two film sheets with inner faces joined together) was cut to 100 mm in width and 200 mm in length in a thermostat chamber at 23°C and measured for 180° blocking peel strength using a slip tester (HEIDON-14, product of Shinto Kagaku Co.) More specifically, the film with inner faces joined to each other (not opened since molding) was placed on a smooth plate with the lower film fixed and the upper film held by a clip. The clip was tied to load meter by a monofilament. Similarly as in the measurement of the 180° peel tack strength, the clip was placed on paper spread on the upper film. The smooth plate was moved at a rate of 150 mm/min. The maximum strength at 180° peeling of the two films is given as the 180° blocking peel strength.

[0027]

(3) Self-tack property

An inflation-molded film (two film sheets with inner faces joined together) was cut to 50 mm in width and 200 mm in length in a thermostat chamber at 23°C, and separated into two films. One film was placed with the outer surface facing upward, and the other film placed with the inner surface facing downward to form an overlap (with the outer face-to-inner face adhesion of the films, avoid pressing of the films with the fingers, etc.). ○ rating is given for films that stick together, and an X rating is for no adhesion. Self-adhesion ○ means self-adhesion of films, while self-adhesion X means no self-adhesion.

[0028]

Polyethylene resins, process oils and film-forming processes used in the examples are given below.

(a) Synthesis of polyethylene resin

A catalyst was prepared according to the method described in Japanese Kokai Patent Application No. Sho 61[1986]-130314. Namely, 2.0 mmol ethylenebis(4,5,6,7-tetrahydroindenyl)zirconium dichloride complex were treated with 1000 mol of methylalumoxane of the Toyo Stouffer Co., diluted with 10 L of toluene and used as a catalyst solution for polymerization shown below.

[0029]

In a stirred 1.5-L-inner volume autoclave type continuous reactor, ethylene and 1-hexene were fed at a 1-hexene content of 83 wt%, and the reaction was carried out at 115°C under a reactor inner pressure of 1300 kg/cm² to obtain a polyethylene resin (hereafter referred to as

PE-1) that is an ethylene-1-hexene copolymer with a MFR of 3.5 g/10 min, density of 0.895 g/cm³ and Q value of 3.1. A similar reaction was carried out with variation of the 1-hexene composition and polymerization temperature to obtain a polyethylene resin (hereafter referred to as PE-2) that is an ethylene-1-hexene copolymer with a MFR of 3.5 g/10 min, density of 0.880 g/cm³ and Q value of 3.3.

[0030]

(b) Process oil

(i) Dynaprocess PW-90, a process oil of Idemitsu Kosan Co. (paraffin oil, average molecular weight: 539, 40°C kinematic viscosity: 95.5 cSt) (hereafter referred to as PW-90)

(ii) Dynaprocess PW-380, a process oil of Idemitsu Kosan Co. (paraffin oil, average molecular weight: 746, 40°C kinematic viscosity: 381.6 cSt) (hereafter referred to as PW-380).

[0031]

(c) Film formation

Polyethylene and process oil were molded into a film by the air-cooled inflation process under the conditions given below.

(Molding conditions) Machine: air-cooled inflation film molding machine of Tomi Co.

Screw diameter: 40 mm ϕ

L/D: 24

Temperature: 130°C

Die diameter: 75 mm ϕ

Die lip: 3 mm

Die temperature: 130°C

Blow ratio: 2.1

Take-up speed: 9 m/min

Film thickness: 50 μ m

[0032]

Application Example 1

A compound obtained by dry blending 98 wt% PE-1 as the polyethylene resin and 2 wt% PW-90 as the process oil was fed into an air-cooled inflation film molding machine to obtain a film which was then evaluated. Evaluation results are given in Table 1.

[0033]

Application Example 2

A compound obtained by dry blending 96 wt% PE-1 as the polyethylene resin and 4 wt% PW-90 as the process oil was fed into an air-cooled inflation film molding machine to obtain a film which was then evaluated. Evaluation results are given in Table 1.

[0034]

Application Examples 3-5

Compounds obtained by dry blending PE-2 as the polyethylene resin and PW-90 as the process oil in the compounding ratios shown in Table 1 were fed into an air-cooled inflation film molding machine to obtain films which were then evaluated. Evaluation results are given in Table 1.

[0035]

Application Examples 6 and 7

Compounds obtained by dry blending PE-2 as the polyethylene resin and PW-380 as the process oil in the compounding ratios shown in Table 1 were fed into an air-cooled inflation film molding machine to obtain films which were then evaluated. Evaluation results are given in Table 1.

[0036]

Comparative Example 1

The polyethylene resin PE-2 was fed into the hopper of an air-cooled inflation film molding machine to form a film which was then evaluated. Evaluation results are given in Table 2. While the 180° peel tack strength was excellent, the 180° blocking peel strength was high with poor film opening property and the self-adhesion was poor.

[0037]

Comparative Example 2

A compound obtained by dry blending 99.5 wt% PE-2 as the polyethylene resin and 0.5 wt% PW-90 as the process oil was fed into an air-cooled inflation film molding machine to obtain a film which was then evaluated. Evaluation results are given in Table 1. While the 180° peel tack strength was excellent, the 180° blocking peel strength was high with poor film opening property and the self-adhesion was poor.

[0038]

Comparative Example 3

A compound obtained by dry blending 75 wt% PE-2 as the polyethylene resin and 25 wt% PW-90 as the process oil was fed into an air-cooled inflation film molding machine. Films could not be formed.

[0039]

Comparative Example 4

A compound obtained by dry blending 99.5 wt% PE-2 as the polyethylene resin and 0.5 wt% PW-380 as the process oil was fed into an air-cooled inflation film molding machine to obtain a film which was then evaluated. Evaluation results are given in Table 1. While the 180° peel tack strength was excellent, the 180° blocking peel strength was high with poor film opening property and the self-adhesion was poor.

[0040]

Comparative Example 5

A compound obtained by dry blending 75 wt% PE-2 as the polyethylene resin and 25 wt% PW-380 as the process oil was fed into an air-cooled inflation film molding machine. Films could not be formed.

[0041]

Table 1

		① 単位	② 実施例 1 2		② 実施例 3 4		② 実施例 5 6		② 実施例 7
③	ポリエチレン系樹脂	MFR	g/10min	3.5	3.5	3.5	3.5	3.5	3.5
		膜厚	μm	0.895	0.895	0.880	0.880	0.860	0.880
		密度	g/cm ³	-	3.1	3.1	3.3	3.3	3.3
		割合	%	99	99	99	94	85	98
④	プロセスオイル	PE-90	%	2	4	2	8	15	-
		PW-380	%	-	-	-	-	-	4
⑤	180° 剥離粘着強度	g	52	21	304	271	63	259	275
	180° ブロッキング剥離強度	g	5.1	3.9	22	14	5.4	15	11
	自己粘着性		-	○	○	○	○	○	○

- Key:
- 1 Unit
 - 2 Application Example ____
 - 3 Polyethylene resin
 - 4 Process oil
 - 5 180° Peel tack strength
 - 6 180° Blocking peel strength

- 7 Self adhesion
- 8 Density
- 9 Q value
- 10 Proportion

[0042]

Table 2

		① 単位	② 比較例		② 比較例		② 比較例
			1	2	3	4	
③ ポリエチレン系樹脂	MFR	g/10min	3.5	3.5	3.5	3.5	3.5
	密度⑧	g/cm ³	0.880	0.880	0.880	0.880	0.880
	⑨ Q値	-	3.3	3.3	3.3	3.3	3.3
	割合⑩	%	100	88.6	75	88.6	75
④ プロセスオイル	PF-80	%	-	0.6	25	-	-
	PF-880	%	-	-	-	0.5	25
⑤ 180° 剝離粘着強度		g	302	300	-	297	-
⑤ 180° ブロッキング剝離強度⑥		g	69	69	-	68	-
⑦ 自己粘着性		-	×	×	-	×	-

- Key:
- 1 Unit
 - 2 Comparative Example ____
 - 3 Polyethylene resin
 - 4 Process oil
 - 5 180° Peel tack strength
 - 6 180° Blocking peel strength
 - 7 Self adhesion
 - 8 Density
 - 9 Q value
 - 10 Proportion

[0043]

Effect of the invention

According to the present invention, a polyethylene resin composition and film therefrom are provided which are desirable for a pressure-sensitive adhesive layer capable of giving a pallet stretch film with pressure-sensitive self-adhesiveness, has good pressure-sensitive adhesiveness between films, can be easily peeled and has good opening properties, while no expensive pressure-sensitive adhesives are used.

Brief description of the figure

Figure 1 is a schematic diagram for a 180° peel tack strength measurement method.

Explanation of symbols

- 1 Film
- 2 Smooth plate
- 3 Load meter
- 4 Monofilament
- 5 Clip
- 6 Paper
- 7 Load

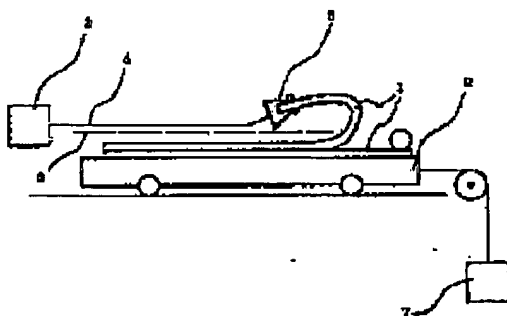

Figure 1